

YOUR MISSION ENABLERS



ACHIEVING EXCELLENCE IS A PASSION

Your Trusted Green Energy Partners

WHAT DO WE

In keeping with its corporate philosophy of 'Conserving Energy and Preserving the Environment', "Winnerspitch" offers off-grid/rooftop and grid connected solar photovoltaic solutions by merging the company's exceptional engineering and integration capabilities along with its allies for technology with globally reputed System Integrators and Original Equipment Manufacturers.

"Winnerspitch" leverages its industry knowledge and state-of-the-art technology tie-ups to provide complete turnkey photo voltaic solutions / Solar Thermal solutions as per client requirements.

As a leading technology company with extensive experience working with diverse sectors, "Winnerspitch" has emerged as a trusted partner in the solar solutions domain.

HOW DO WE

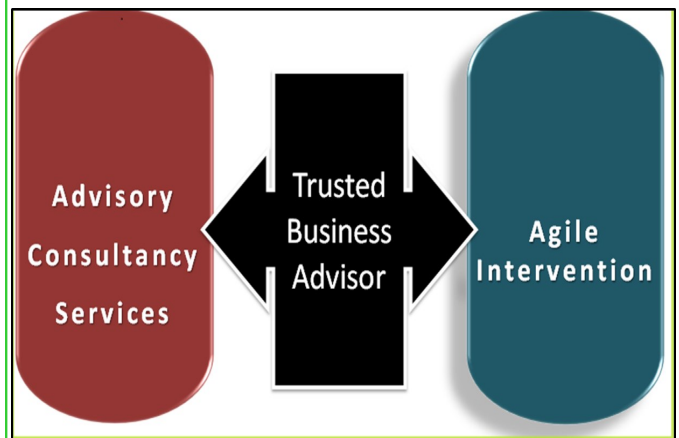

END TO END EMPOWERMENT

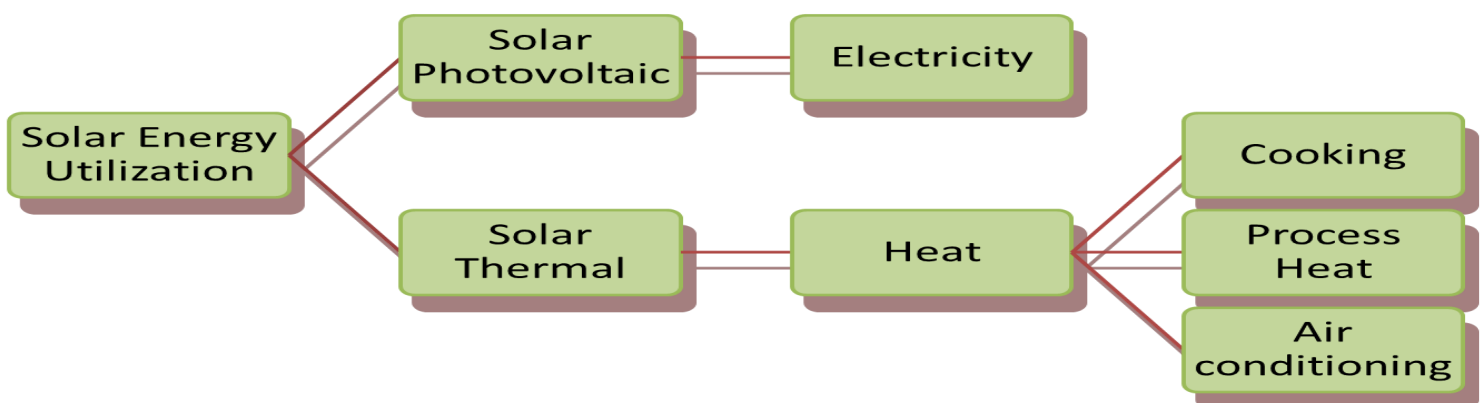

OFFERING INCLUDE

- ◇ Customized plant design for specific applications
- ◇ Best in-class integration capabilities, reliability and quality
- ◇ Robust performance under diverse climatic conditions
- ◇ Stabilized power delivery and continued monitoring of electrical performance
- ◇ Top notch technology consultants with International/National experience
- ◇ Easy to install, maintain and operate

Registered Office :

Winnerspitch Energy Private Limited.

203-207, 1/42, LALITA PARK, LAXMI NAGAR, VIKAS MARG, DELHI-110092

Mobile :+919810394968,+919937731700

Tel/Fax :+91-124-423 4968

Email : sales@winnerspitch.net URL : www.winnerspitch.com